

# Bitpower Sedna O11DXL for LIAN LI O11 DYNAMIC (front)-P5D v1

## Accessories

**1** BPTA-WDPO11DXLA-P5D 1 SET

**2** Panel 1 PC

**3** Outer Baffle(Down) 1 PC

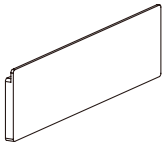

**4** Inside Baffle(Up) 1 PC

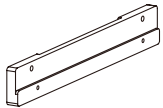

**5** Inside Baffle(Down) 1 PC

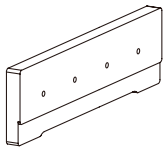

**6** Outer Baffle(Up) 1 PC

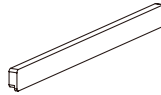

**7** M3x12 Screw 6 PCS



**8** M3x8 Screw 2 PCS



**9** 3PIN/4PIN Transfer4PIN 1 PC

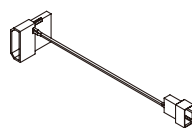

**10** BPTA-EFW 1 PC



**11** TA-EXAIR 1 PC



**12** M2.5x6 Screw 9 PCS



**13** M3x10 Screw 6 PCS



**14** Washer 6 PCS



**15** M3 Nut 6 PCS



**16** Nut 2 PCS

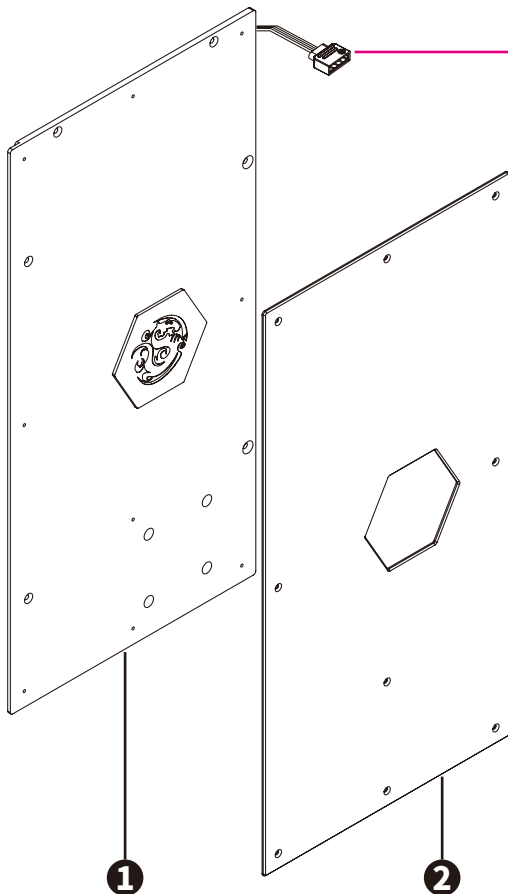

★ Digital RGB PIN on **1** motherboard or **2** other equipment.

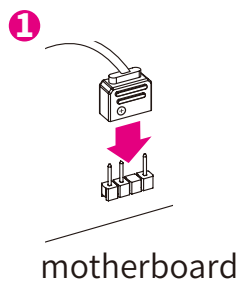

**2**  BPTA-DRGBMFC

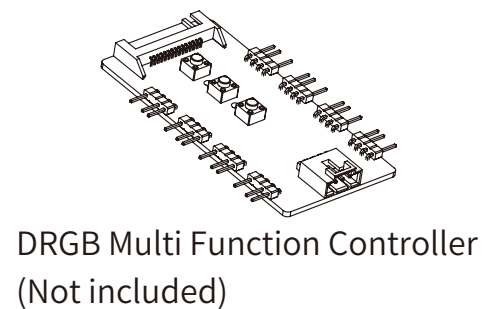

## Power Supply and Pump

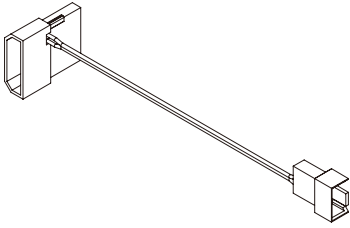

★ Other than from the motherboard, the P5D pump can be powered from the power supply via a patch cord.

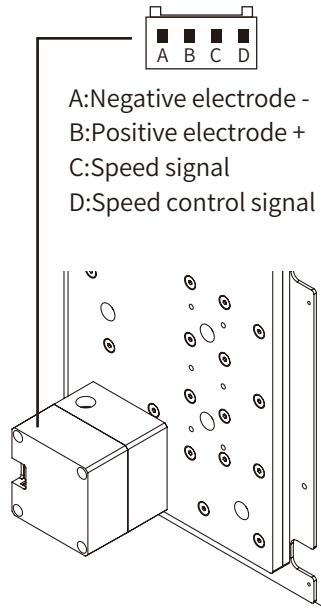

Pump Spec
Rated voltage : 12V DC
Power consumption : 20W
Maximum flow : 14.5±15% L/min
Noise : ≤ 40dBA
Ambient temperature : -25~70°C
PWM : Yes
MTBF : 15,000 hours
Warranty : 2 years

### TA-EXAIR



It is recommended to install the air-exhaust fitting on the reservoir, above the water line.

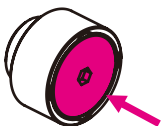

Press the button to release the air.

### BP-ETW

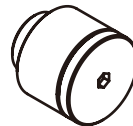

It is recommended to install the water-exhaust fitting at the lowest point of the water cooling system.

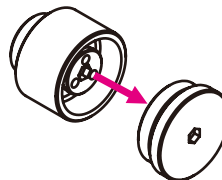

Unscrew the top of the water-exhaust fitting.

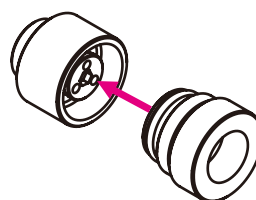

Replace with the water-exhaust part. When screwing in the part, water will start to discharge, it is recommended to connect tubing beforehand to control the water outflow.



## Water

Choose your desired dye color and mix it with pure distilled water. Pour the water mix into the reservoir via the water filling hole. Once the reservoir is 90% full, turn on the power supply for the pump to run and let the air exit the loop. Turn off the power supply when the reservoir is near empty. Repeat until all the air has exited the loop.

(In order to power the pump only, connect the power switch connector to the 24 pin cable of the power supply. This will allow the power supply to bypass the motherboard and make the pump work alone.)

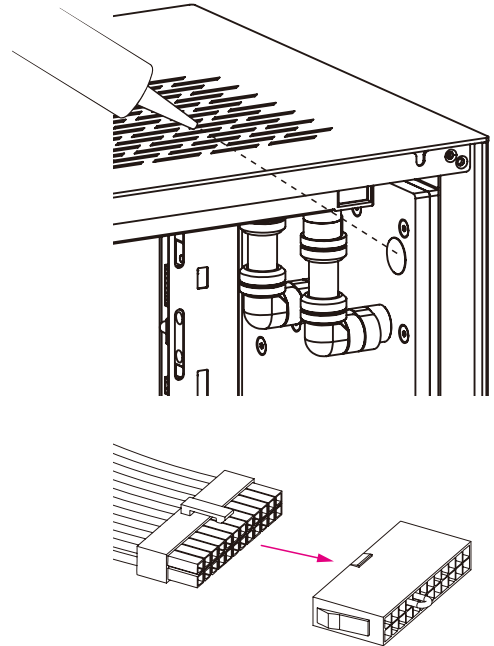

## Product Warranty Rules

The warranty will be void if any of the situations below happen.

### Water Block

- The CPU block and the screws in it has any trace of disassemble.
- The top plate inlet and outlet ports, due to improper use of external forces, are cracked.

### Radiator

- The fin of the radiator are broken or deformed due to improper use of external forces.
- The inlet and outlet of the radiator are cracked due to improper use of external forces.

### Fitting

- There are signs of damage caused by instrument clamping on the fittings.

### PUMP

- Pump damage from pump operation without any liquid.
- Pump damage caused by water leak on the pump's PCB.
- Water tank has been separated from the pump.

### Fan

- Fan damaged by water leak.

**for BPTA-WDPO11DXLA-P5D**

**step 1**

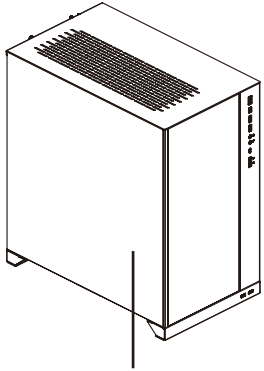

PC-O11 Dynamic XL  
(Not included)

**step 2**

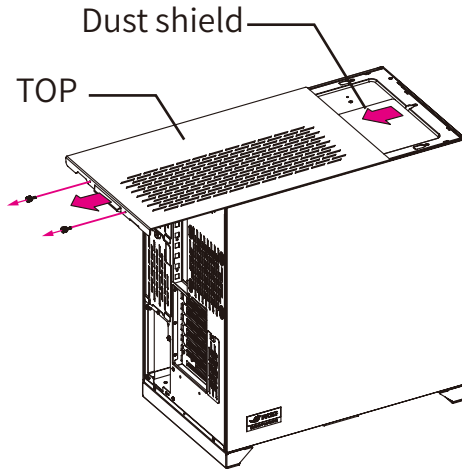

**step 3**

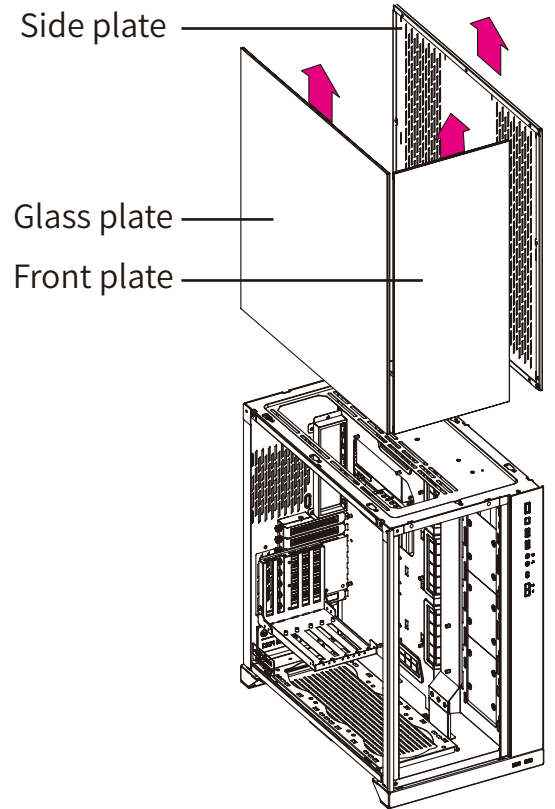

**step 4**

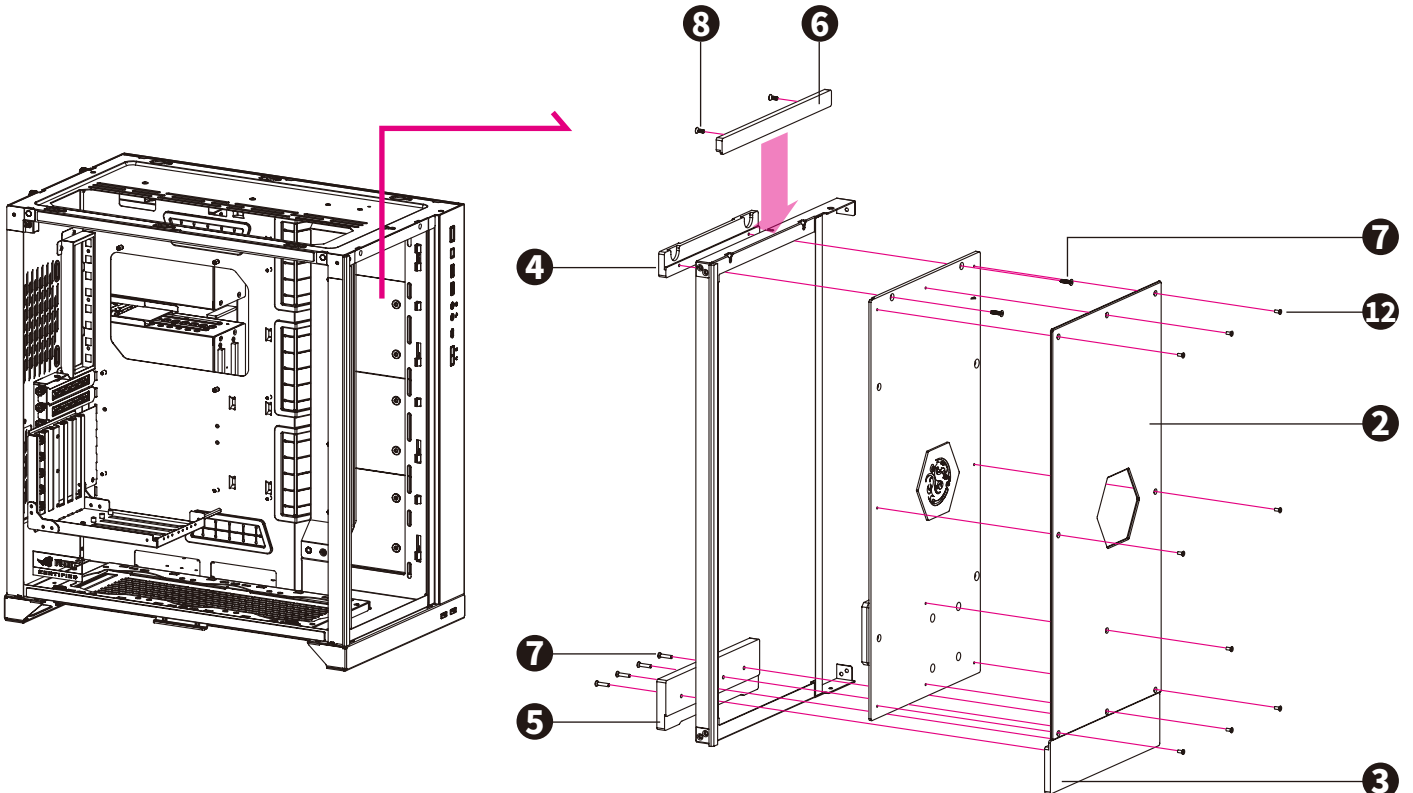



**Recommended installation method for BPTA-WDPO11DXLA-P5D**

**Accessories(additional purchases)**

- |                            |       |                        |      |
|----------------------------|-------|------------------------|------|
| <b>A</b> BP-NLXF360-F4PB   | 1PC   | <b>H</b> BP-WTP-C06    | 3PCS |
| <b>B</b> BPTA-CPUMS-SKI    | 1PC   | <b>I</b> BP-WTP-C61    | 1PC  |
| <b>C</b> BP-VG2080RD       | 1PC   | <b>J</b> BPTA-DRGBMFC  | 1PC  |
| <b>D</b> BP-NCCLT14AC-L500 | 4PCS  | <b>K</b> BP-PFANMFH    | 1PC  |
| <b>E</b> BP-EML14          | 14PCS | <b>L</b> BP-DG14AALPII | 2PCS |
| <b>F</b> BP-90R            | 8PCS  |                        |      |
| <b>G</b> BPTA-EXAIR        | 1PC   |                        |      |

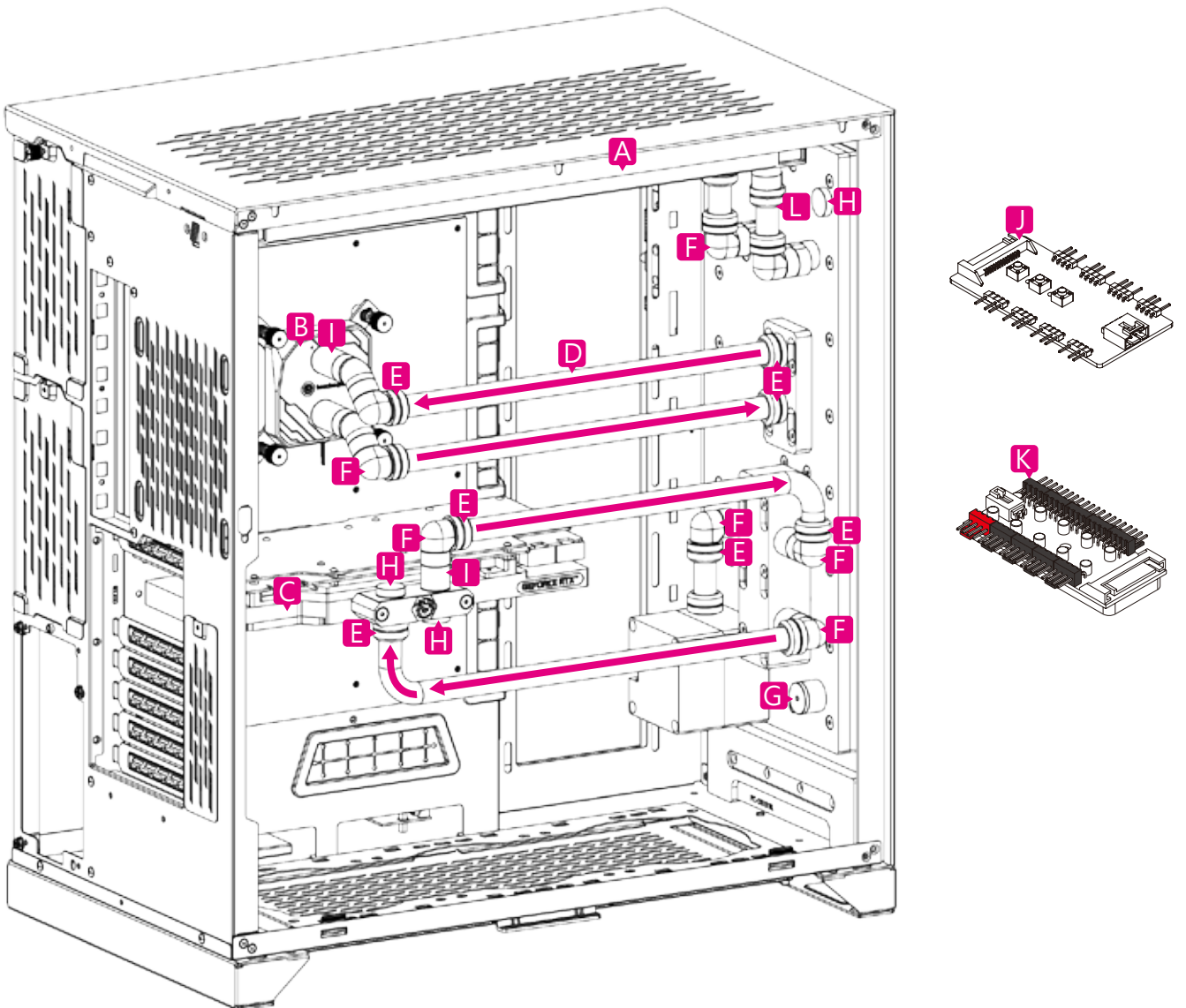

**for BPTA-WDPO11DA-P5D**

**step 1**

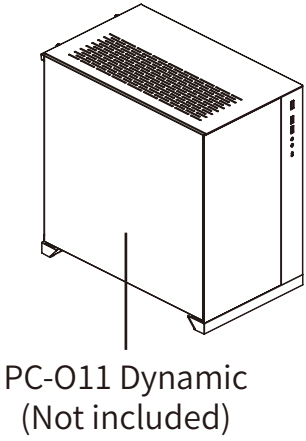

**step 2**

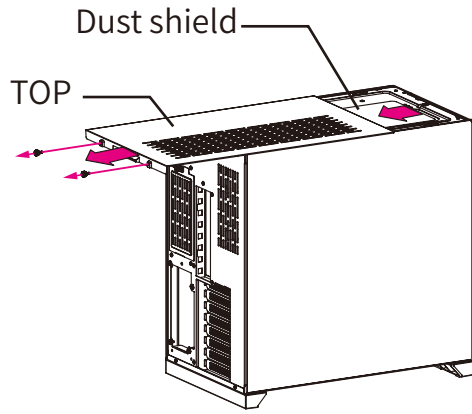

**step 3**

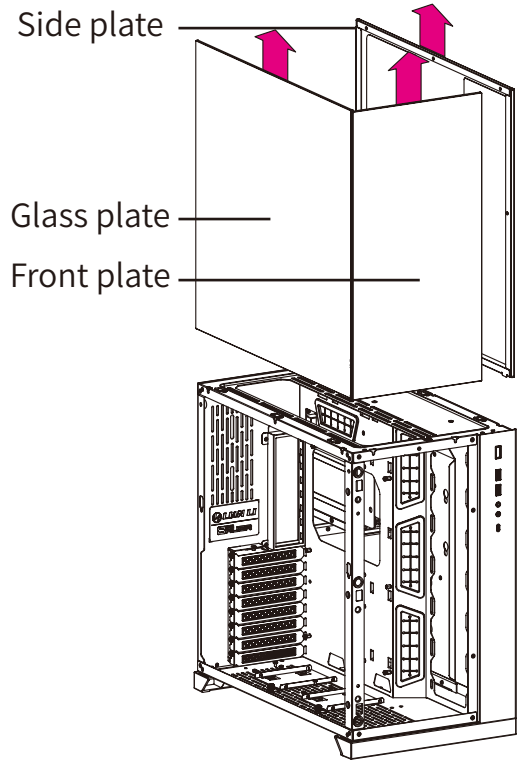

**step 4**

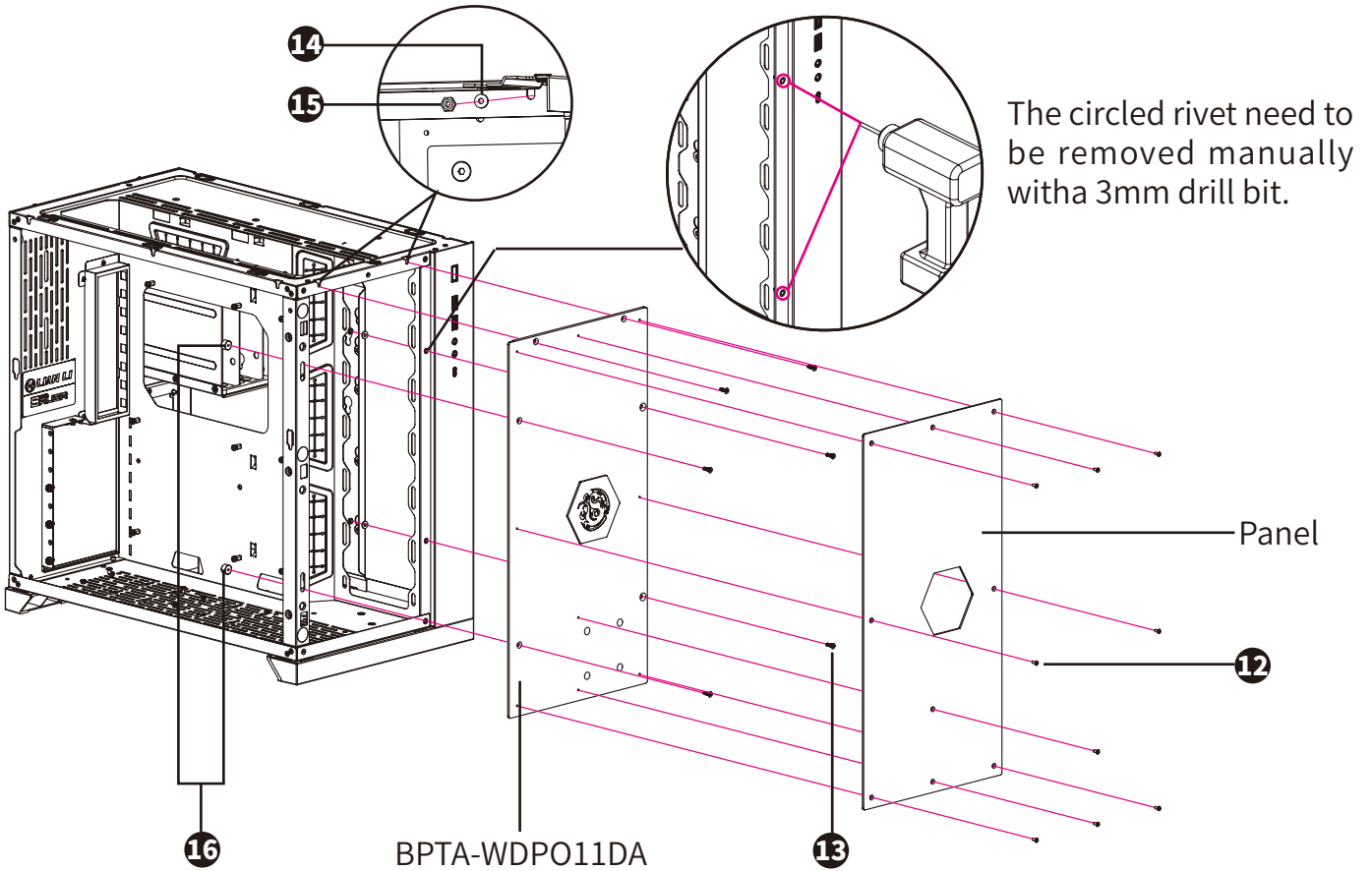



**Recommended installation method for BPTA-WDPO11DA-P5D**

**Accessories(additional purchases)**

- |                            |       |                            |      |
|----------------------------|-------|----------------------------|------|
| <b>A</b> BPTA-NLSS360-F2PB | 1PC   | <b>H</b> BP-TB             | 1PC  |
| <b>B</b> BPTA-CPUMS-DRGB   | 1PC   | <b>I</b> BP-RG             | 1PC  |
| <b>C</b> BP-VG2080RD       | 1PC   | <b>J</b> BP-WTP-C06        | 3PCS |
| <b>D</b> BPTA-FX2212       | 3PCS  | <b>K</b> BP-WTP-C60        | 1PC  |
| <b>E</b> BP-DG14AALPII     | 2PCS  | <b>L</b> BP-NCCLT14AC-L500 | 4PCS |
| <b>F</b> BP-EML14          | 10PCS | <b>M</b> BP-PFANMFH        | 1PC  |
| <b>G</b> BP-90R            | 6PCS  | <b>N</b> BPTA-DRGBMFC      | 1PCS |

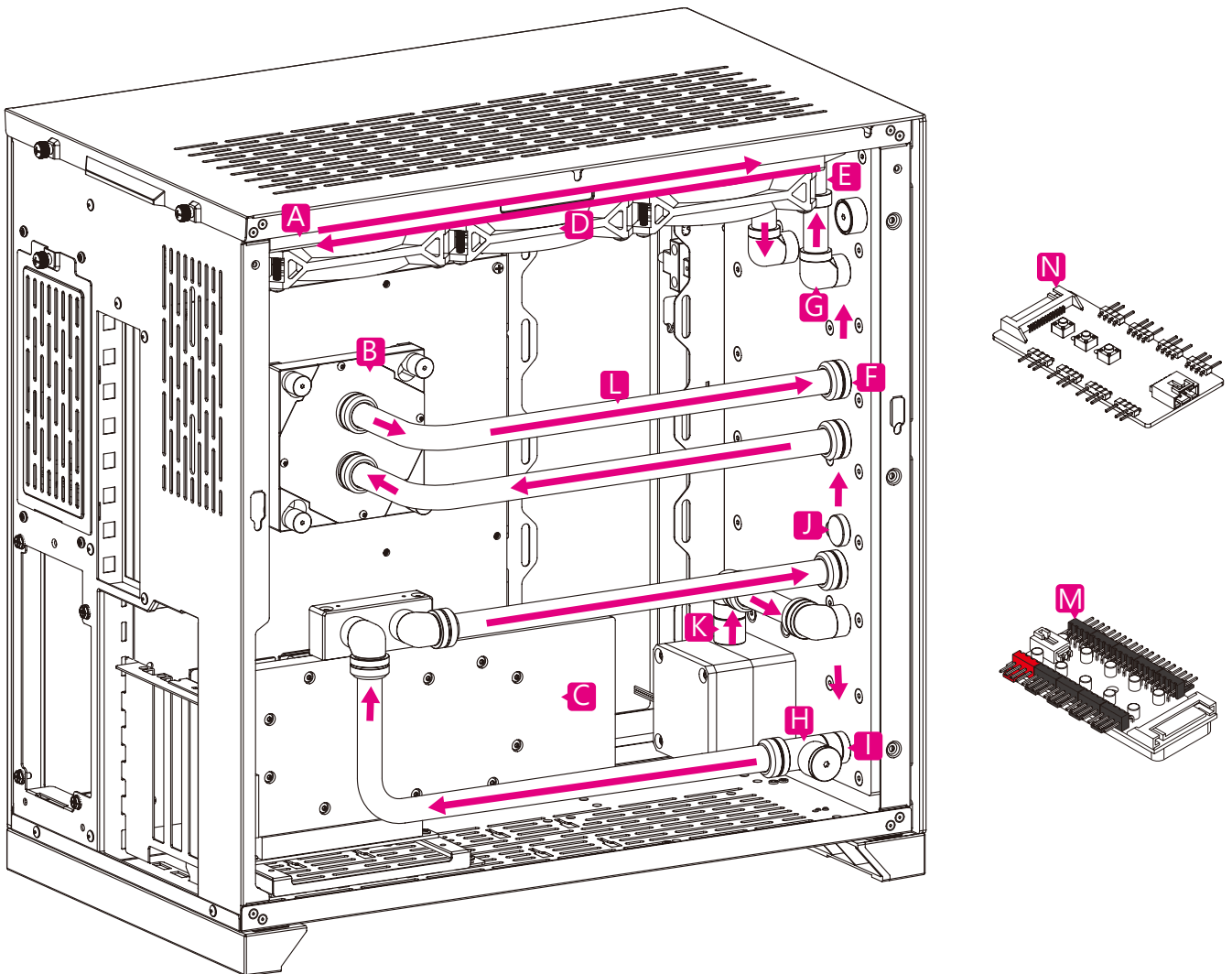





## Notice

- Before filling in the water, please make sure all the components are installed correctly. To prevent any leakage which may damage the PC components, please perform a 24-hour leaking test with only the pump connected to the power supply.
- Bitspower reserves the right to change the product design and interpretations. These are subject to change without notice. Product colors and accessories are based on the actual product.
- When using leak tester on water cooling loop, in order to avoid product damage due to excessive pressure, the input pressure should not exceed  $0.5\text{kg/cm}^2$  (Bar). If the product is damaged due to excessive pressure, it will be borne by the customer. Forbidden to use the leak tester when there is water in the loop or the pump is running.
- Bitspower recommends that consumers add the Bitspower dye to distilled water or purified water for their water-cooling liquid. If the consumer chooses different water-cooling liquids, the resulting impurities may cause peeling of the coating on some of the hardware, water channels blockage by built-up residue, improper operation of the water pump, water tank tube breakage, and o-rings deformation leading to leakage. Any issues related to the use of inappropriate water-cooling liquid will be the responsibility of the consumer. Do not turn on the pump if the reservoir is empty.



# Bitpower Sedna O11DXL for LIAN LI O11 DYNAMIC (front)-P5D

V1

## 配件

- |                              |     |                      |     |                     |     |
|------------------------------|-----|----------------------|-----|---------------------|-----|
| <b>1</b> BPTA-WDPO11DXLA-P5D | 1 組 | <b>6</b> 外固定夾板 (上)   | 1 個 | <b>11</b> 排氣接頭      | 1 個 |
| <b>2</b> 面板                  | 1 片 | <b>7</b> M3x12 螺絲    | 6 支 | <b>12</b> M2.5x6 螺絲 | 9 支 |
| <b>3</b> 外固定夾板 (下)           | 1 個 | <b>8</b> M3x8 螺絲     | 2 支 | <b>13</b> M3x10 螺絲  | 6 支 |
| <b>4</b> 內固定夾板 (上)           | 1 個 | <b>9</b> 大 4PIN 供電線材 | 1 個 | <b>14</b> 墊片        | 6 個 |
| <b>5</b> 內固定夾板 (下)           | 1 個 | <b>10</b> 洩水接頭       | 1 個 | <b>15</b> M3 螺帽     | 6 個 |
|                              |     |                      |     | <b>16</b> 手轉螺帽      | 2 個 |

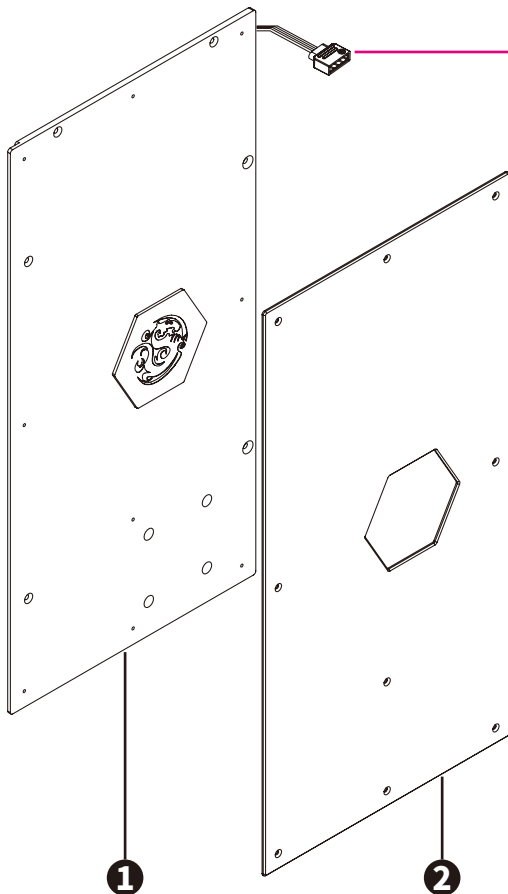

★請接**1**主版或**2**其他設備的 DRGB 插槽

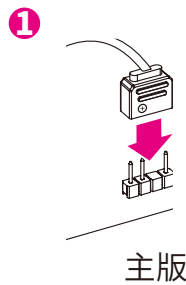

**2** BPTA-DRGBMFC

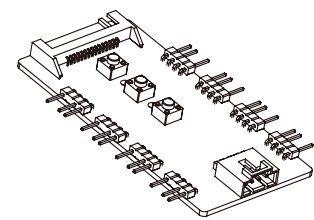

DRGB 控制器 (不包括)

### 供電與馬達

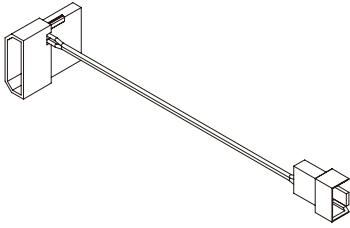

★ P5D 馬達除了可由主機板供電外，亦可透過轉接線由電源供應器直接供電。

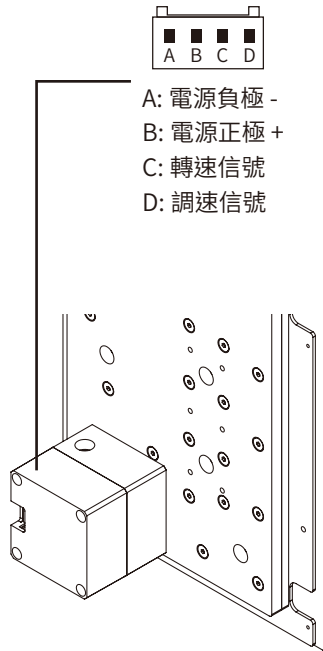

#### 水泵規格

額定電壓：12V DC
功耗：20W
最大流量：14.5±15% L/min
噪音：≤ 40dBA
環境溫度：-25~70°C
PWM：有
使用壽命：15,000 小時
保固：2 年

### TA-EXAIR



建議將排氣接頭安裝於水箱且在水位之上。

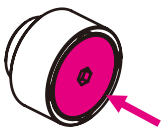

將按鈕按下即可排氣。

### BP-ETW

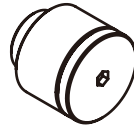

建議將洩水接頭安裝於水冷系統的最低點。

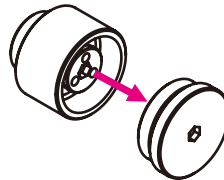

將洩水接頭上蓋旋起。

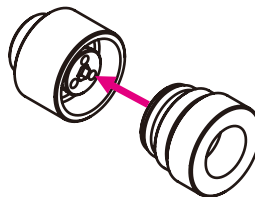

換上洩水配件，旋入配件過程中即會逐漸洩水，建議外接管線以利洩水。

### 注水

選擇喜好的水冷濃縮液顏色，以純淨水調合，由”填水孔”注入至水箱九分滿，接著利用”24PIN 跳線開關”啟動電源，讓水路中的空氣集中至水箱排出，再依水量繼續添加至水箱九分滿左右即可。

(24PIN 跳線開關用途：需無經主板開啟 ATX 電源時，使電源直接開啟供電。)

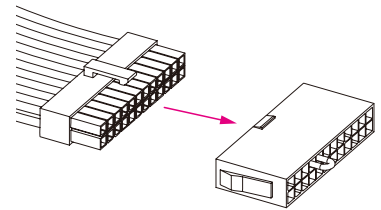
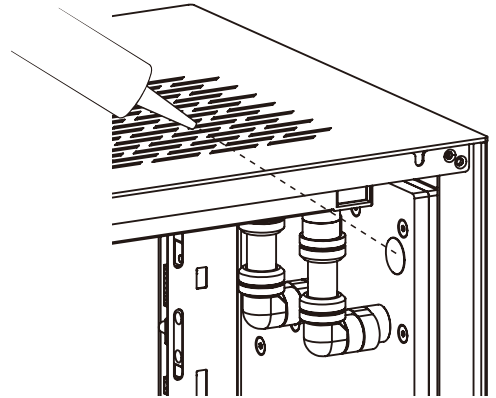

### 產品保修規範

質保期時效，送修的產品凡有以下狀況，不在保修範圍內。

#### 水冷頭

- 冷頭自體螺絲，有拆裝痕跡，整套產品失保。
- 頂部的進出口，因為外力使用不當導致開裂。

#### 冷排

- 因為外力使用不當導致冷排水道破裂漏水。
- 進出水孔因為外力使用不當導致開裂。

#### 接頭

- 有器械夾持導致的損傷痕跡。

#### 水泵

- 無水通電導致水泵燒毀。
- 底部 pcb 進水燒毀。
- 水箱底座與水泵不可拆解，一經拆解即不保固。

#### 風扇

- 進水燒毀。

**BPTA-WDPO11DXLA-P5D 參考**

**步驟 1**

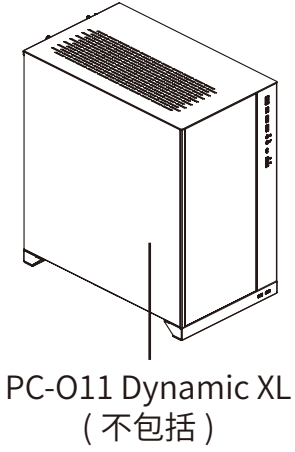

**步驟 2**

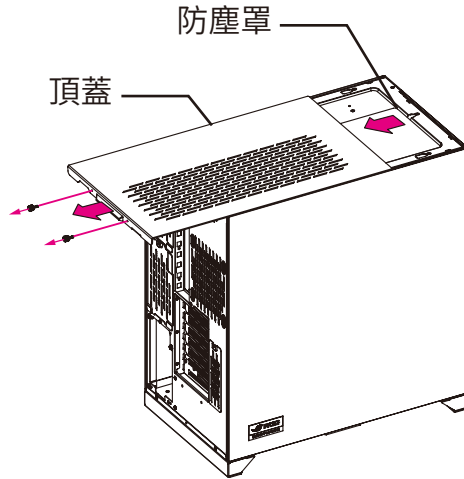

**步驟 3**

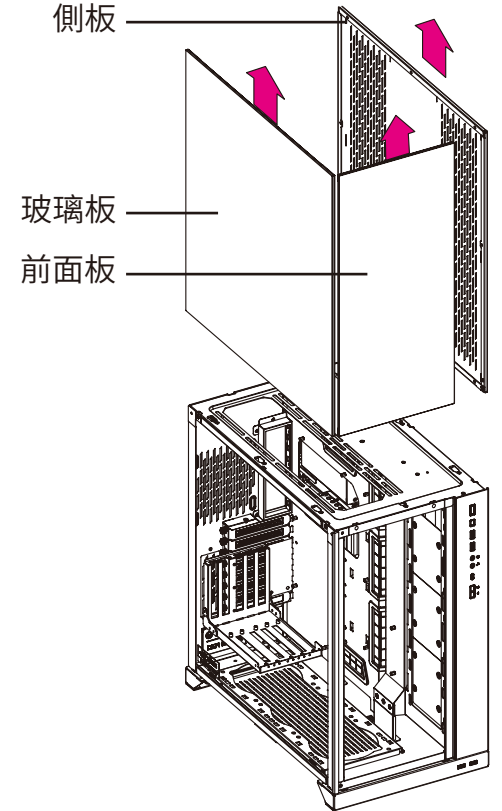

**步驟 4**

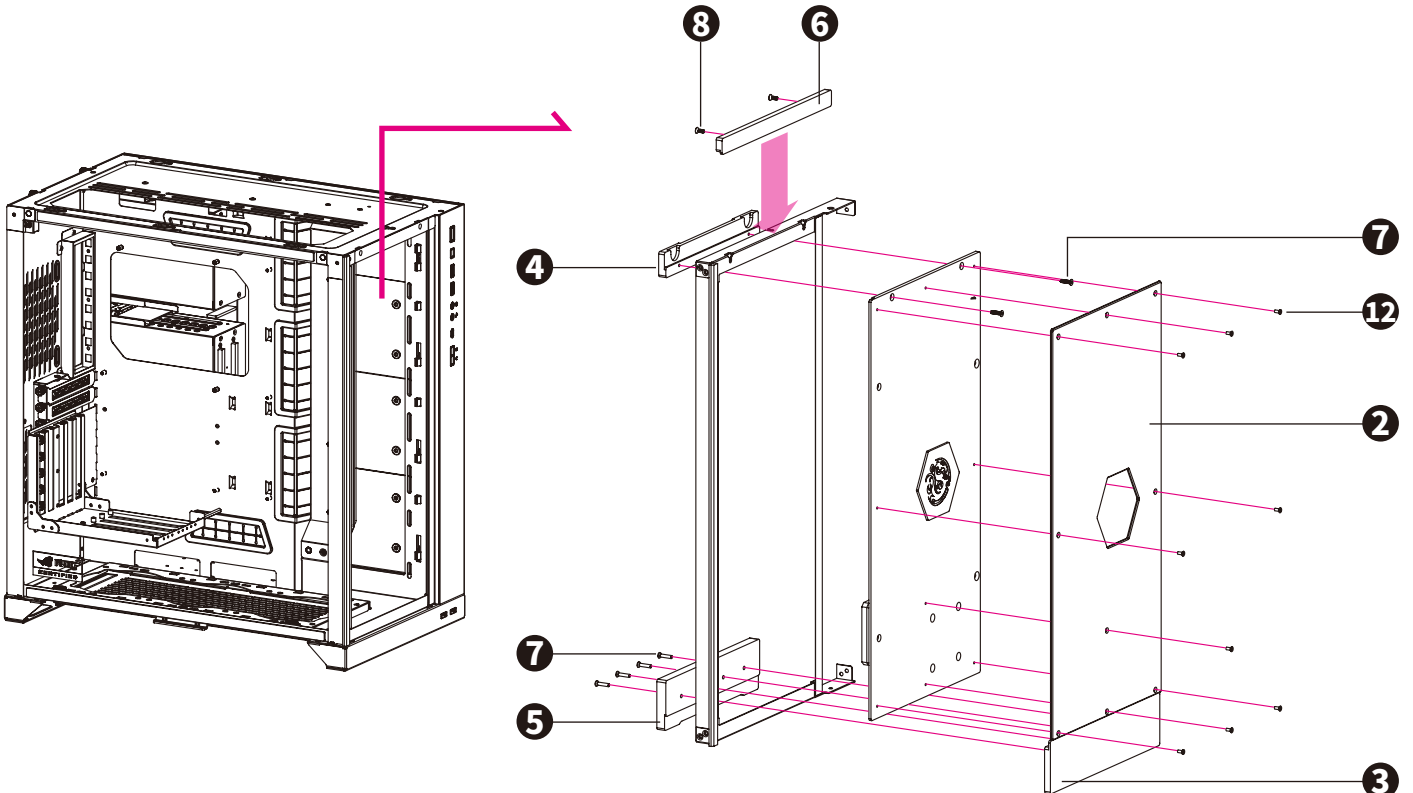



**BPTA-WDPO11DXLA-P5D 建議安裝方式**

**主件說明 (需另購)**

<b>A</b> BP-NLXF360-F4PB	1PC	<b>H</b> BP-WTP-C06	3PCS
<b>B</b> BPTA-CPUMS-SKI	1PC	<b>I</b> BP-WTP-C61	1PC
<b>C</b> BP-VG2080RD	1PC	<b>J</b> BPTA-DRGBMFC	1PC
<b>D</b> BP-NCCLT14AC-L500	4PCS	<b>K</b> BP-PFANMFH	1PC
<b>E</b> BP-EML14	14PCS	<b>L</b> BP-DG14AALPII	2PCS
<b>F</b> BP-90R	8PCS		
<b>G</b> BPTA-EXAIR	1PC		

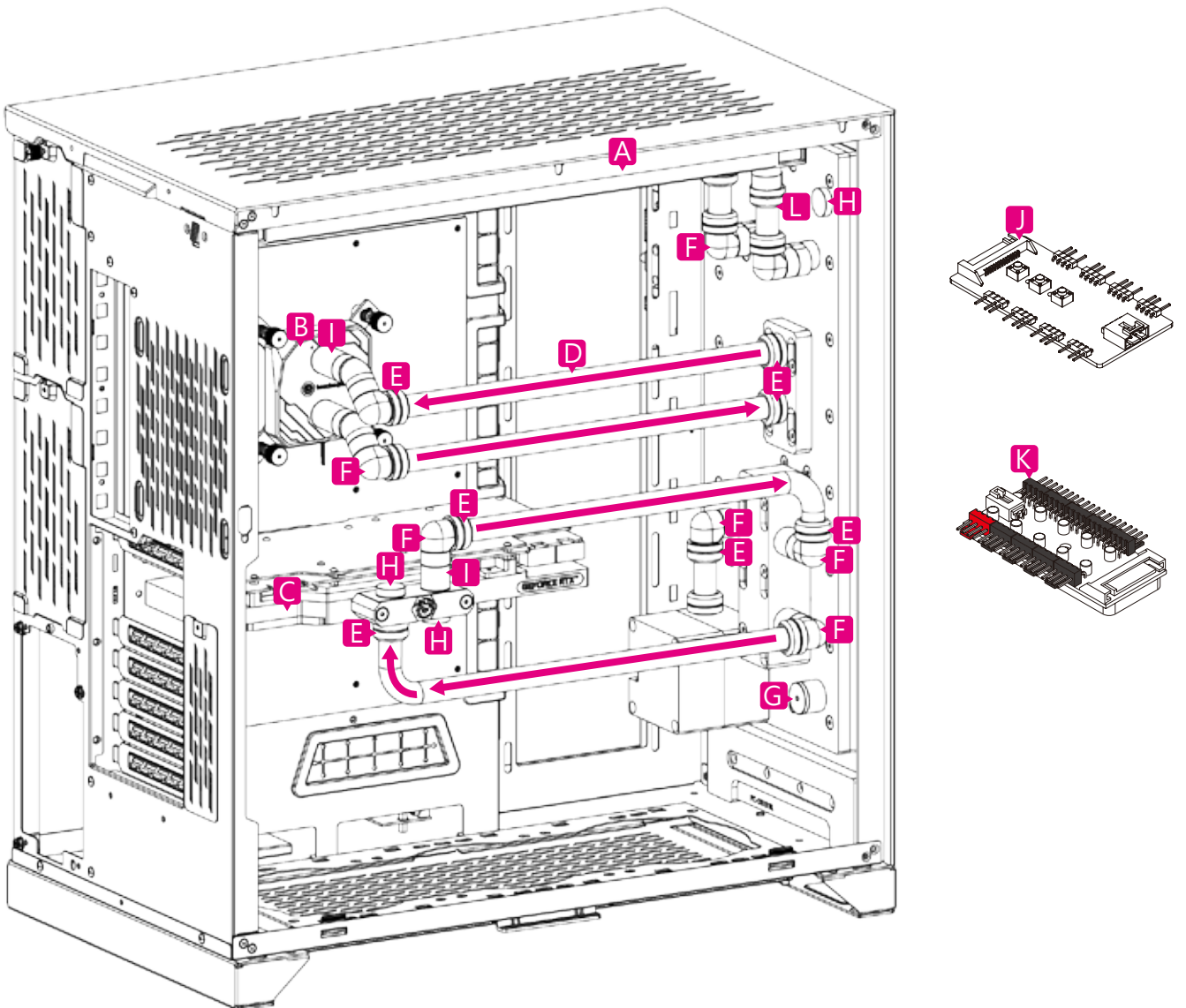

**BPTA-WDPO11DA-P5D 參考**

**步驟 1**

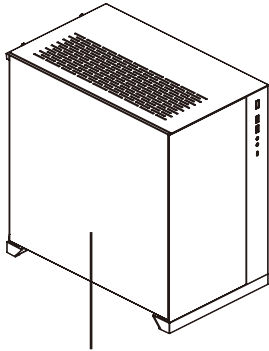

PC-O11 Dynamic  
(不包括)

**步驟 2**

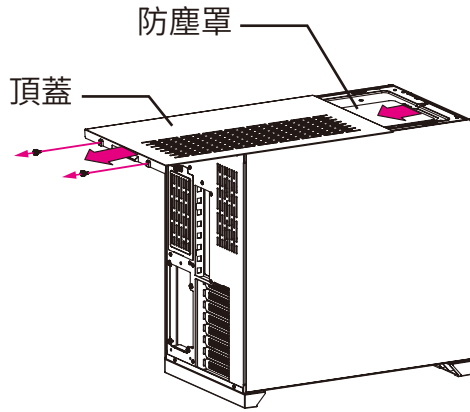

**步驟 3**

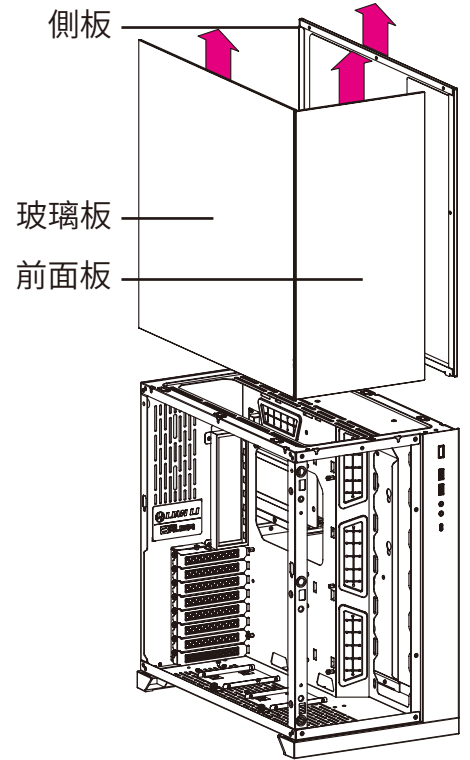

**步驟 4**

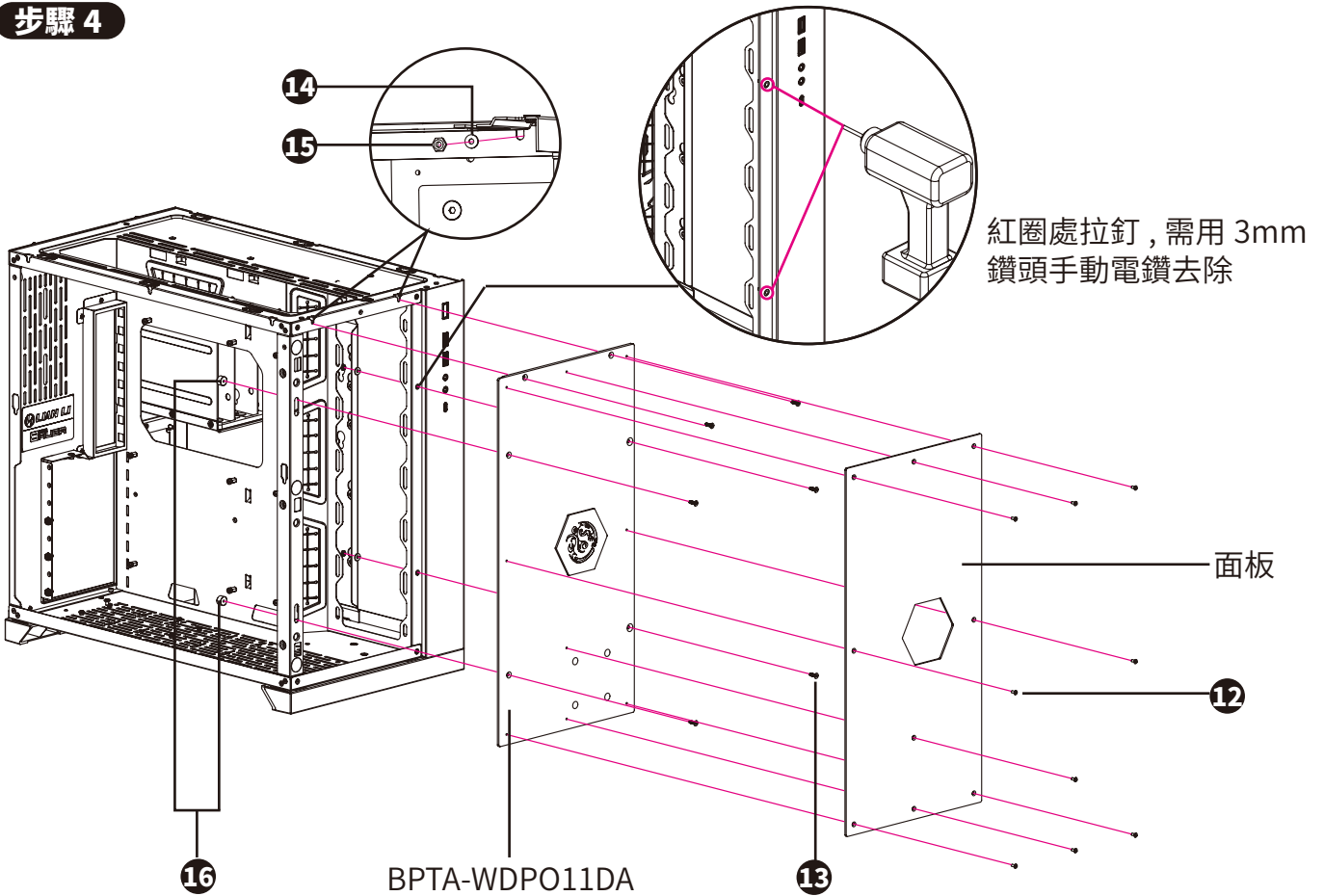



**BPTA-WDPO11DA-P5D 建議安裝方式**

**主件說明 ( 需另購 )**

<b>A</b> BPTA-NLSS360-F2PB	1PC	<b>H</b> BP-TB	1PC
<b>B</b> BPTA-CPUMS-DRGB	1PC	<b>I</b> BP-RG	1PC
<b>C</b> BP-VG2080RD	1PC	<b>J</b> BP-WTP-C06	3PCS
<b>D</b> BPTA-FX2212	3PCS	<b>K</b> BP-WTP-C60	1PC
<b>E</b> BP-DG14AALPII	2PCS	<b>L</b> BP-NCCLT14AC-L500	4PCS
<b>F</b> BP-EML14	10PCS	<b>M</b> BP-PFANMFH	1PC
<b>G</b> BP-90R	6PCS	<b>N</b> BPTA-DRGBMFC	1PCS

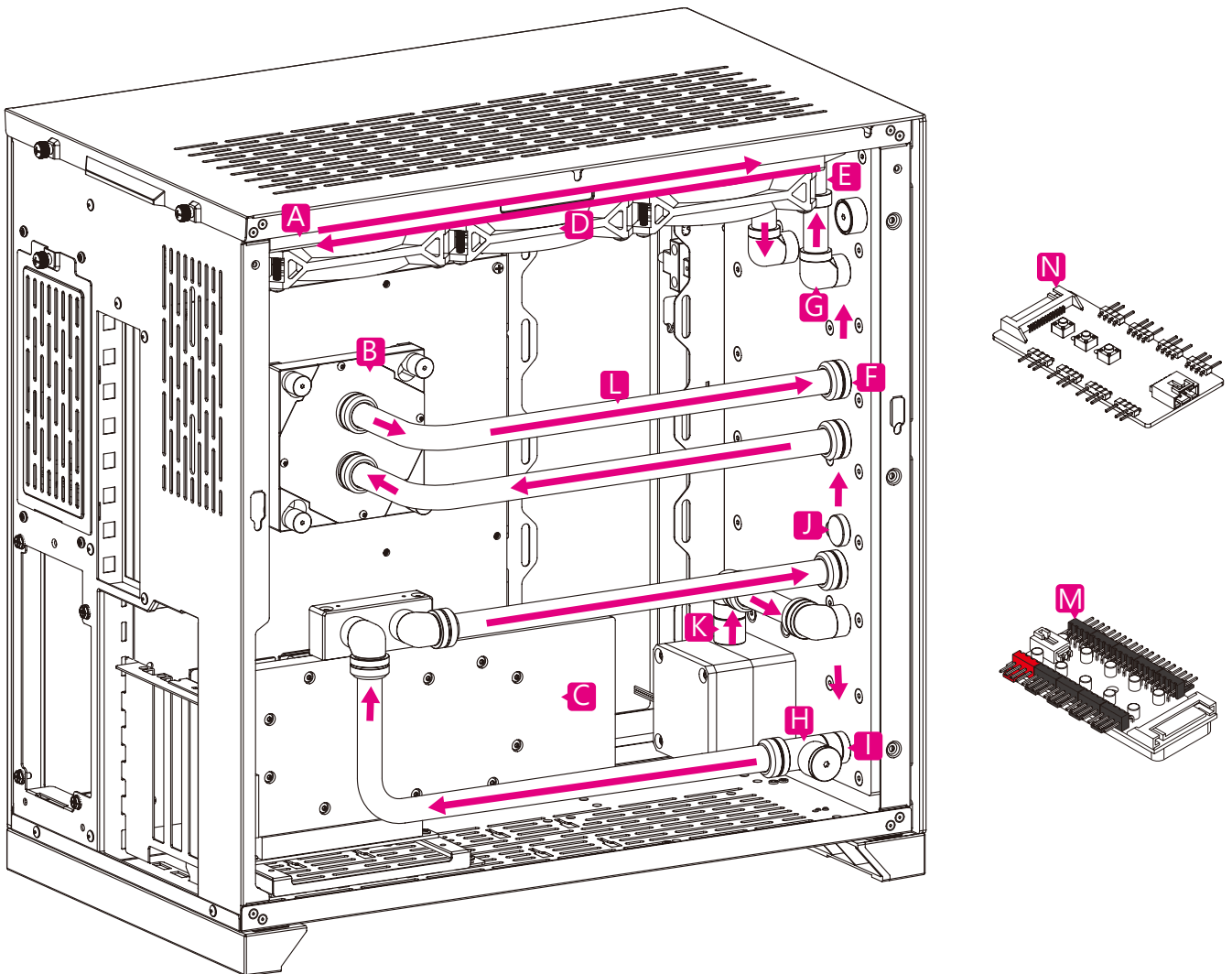



## 注意

- 跑水前，請先確認所有零件已安裝在正確的位置上，在不開主機，單開水泵的情況下，進行 24 小時的跑水測試，確保無漏水情況後再開主機，避免發生漏水而導致電腦零件的損壞。
- 本公司保留對產品的設計更改以及解釋的權力，如有更動恕不另行通知，產品顏色與配件以實物為準。
- 當使用測氣產品測試水路時，為避免由于壓力過大導致產品損壞，輸入的壓力請不要超過  $0.5\text{kg/cm}^2$  (Bar), 如因壓力過大造成產品損壞，將由客戶自行承擔。嚴禁客戶在水路有水及水泵開啟的情況下進行氣體飽壓測試。
- Bitspower 建議消費者使用蒸餾水、純淨水，加入 Bitspower 的染劑作為水冷液使用；如客戶自行選購的水冷液導致電鍍層剝落、水道堵塞、水泵轉動不正常、水箱管破裂或密封圈變型以致漏水等及其它不可抗力之問題時，消費者自行承擔相關產品責任。未注水前，請勿啟動水泵電源。

# Bitspower Sedna O11DXL for LIAN LI O11 DYNAMIC (front)-P5D

V1

## 配件

- |                              |     |                      |     |                     |     |
|------------------------------|-----|----------------------|-----|---------------------|-----|
| <b>1</b> BPTA-WDPO11DXLA-P5D | 1 组 | <b>6</b> 外固定夹板 (上)   | 1 个 | <b>11</b> 排气接头      | 1 个 |
| <b>2</b> 面板                  | 1 片 | <b>7</b> M3x12 螺丝    | 6 支 | <b>12</b> M2.5x6 螺丝 | 9 支 |
| <b>3</b> 外固定夹板 (下)           | 1 个 | <b>8</b> M3x8 螺丝     | 2 支 | <b>13</b> M3x10 螺丝  | 6 支 |
| <b>4</b> 内固定夹板 (上)           | 1 个 | <b>9</b> 大 4PIN 供电线材 | 1 个 | <b>14</b> 垫片        | 6 个 |
| <b>5</b> 内固定夹板 (下)           | 1 个 | <b>10</b> 泄水接头       | 1 个 | <b>15</b> M3 螺帽     | 6 个 |
|                              |     |                      |     | <b>16</b> 手转螺帽      | 2 个 |

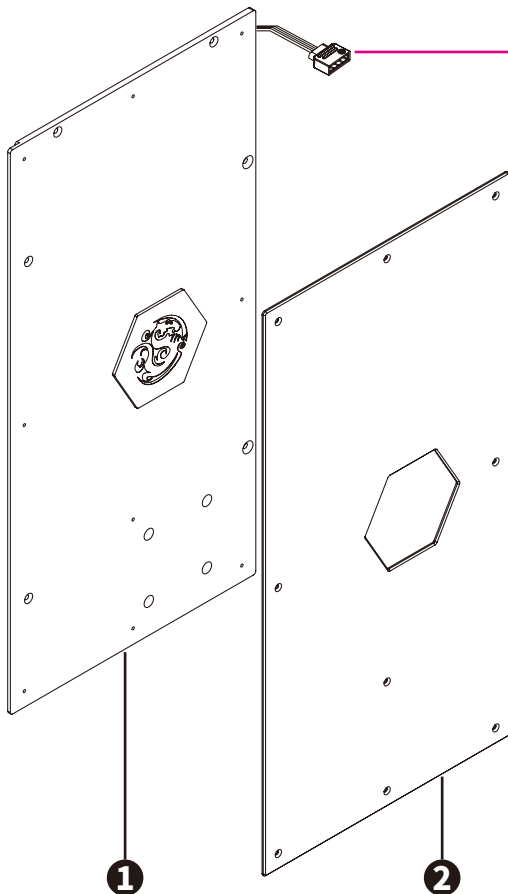

★ 请接**1**主版或**2**其他设备的 DRGB 插槽

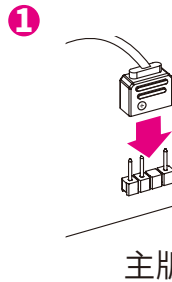

**2** BPTA-DRGBMFC

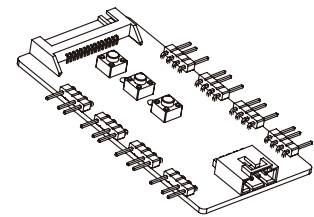

DRGB 控制器 (不包括)

### 供电与马达

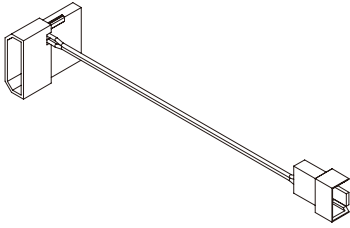

★ P5D 水泵除了可由主机板供电外，亦可透过转接线由电源供应器直接供电。

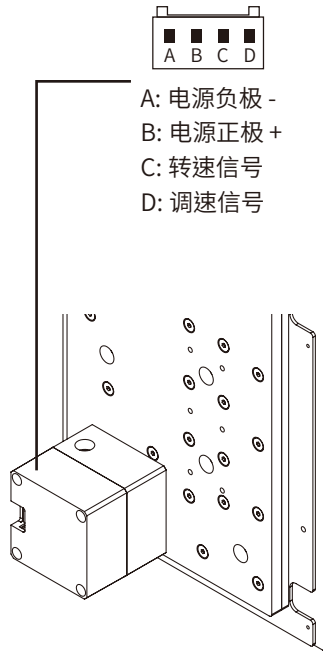

#### 水泵规格

额定电压：12V DC
功耗：20W
最大流量：14.5±15% L/min
噪音：≤ 40dBA
环境温度：-25~70°C
PWM：有
使用寿命：15,000 小时
保固：2 年

### TA-EXAIR



建议将排气接头安装于水箱且在水位之上。

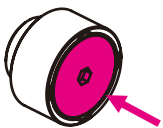

將按鈕按下即可排氣。

### BP-ETW

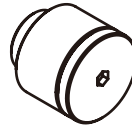

建议将泄水接头安装于水冷系统的最低点。

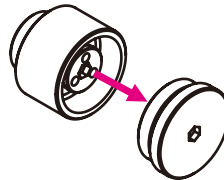

将泄水接头上盖旋起。

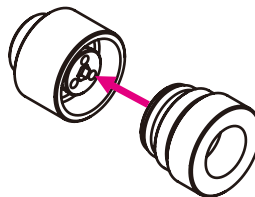

换上泄水配件，旋入配件过程中即会逐渐泄水，建议外接管线以利泄水。

### 注水

选择喜好的水冷浓缩液颜色，以纯净水调合，由”填水孔”注入至水箱九分满，接着利用”24PIN 跳线开关”启动电源，让水路中的空气集中至水箱排出，再依水量继续添加至水箱九分满左右即可。  
(24PIN 跳线开关用途：需无经主板开启 ATX 电源时，使电源直接开启供电。)

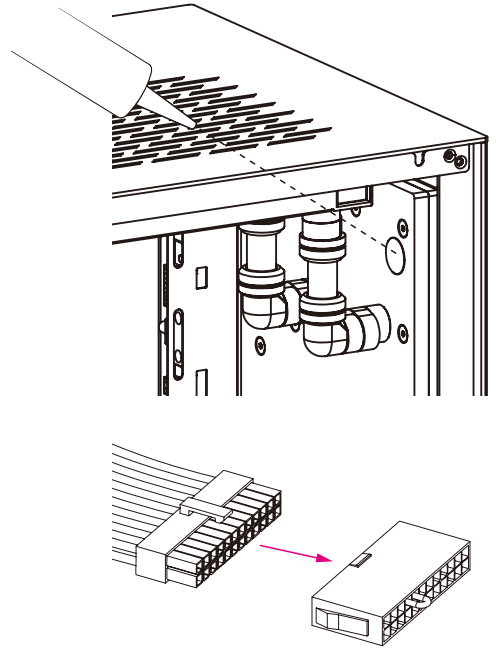

### 产品保修规范

质保期时效，送修的产品凡有以下状况，不在保范围内。

#### 水冷头

- 冷头自体螺丝，有拆装痕迹，整套产品失保。
- 顶部的进出口，因为外力使用不当导致开裂。

#### 冷排

- 因为外力使用不当导致冷排水道破裂漏水。
- 进出水孔因为外力使用不当导致开裂。

#### 接头

- 有器械夹持导致的损伤痕迹。

#### 水泵

- 无水通电导致水泵烧毁。
- 底部 pcb 进水烧毁。
- 水箱底座与水泵不可拆解，一经拆解即不保固。

#### 风扇

- 进水烧毁。

**BPTA-WDPO11DXLA-P5D 参考**

**步骤 1**

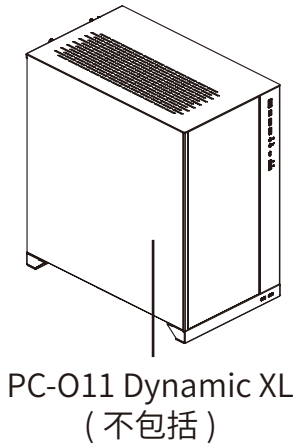

**步骤 2**

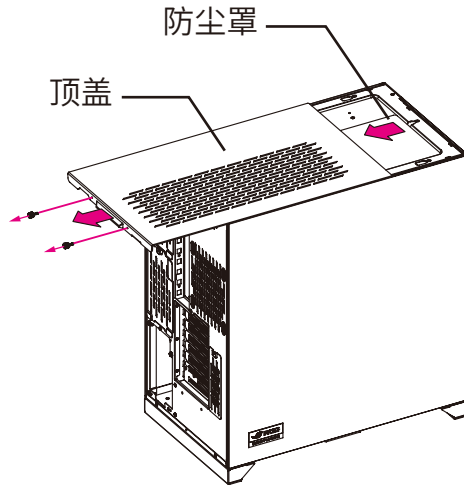

**步骤 3**

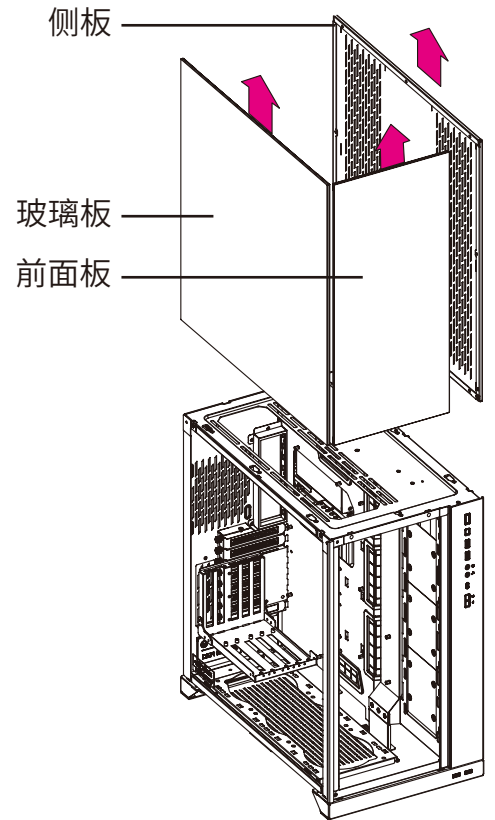

**步骤 4**

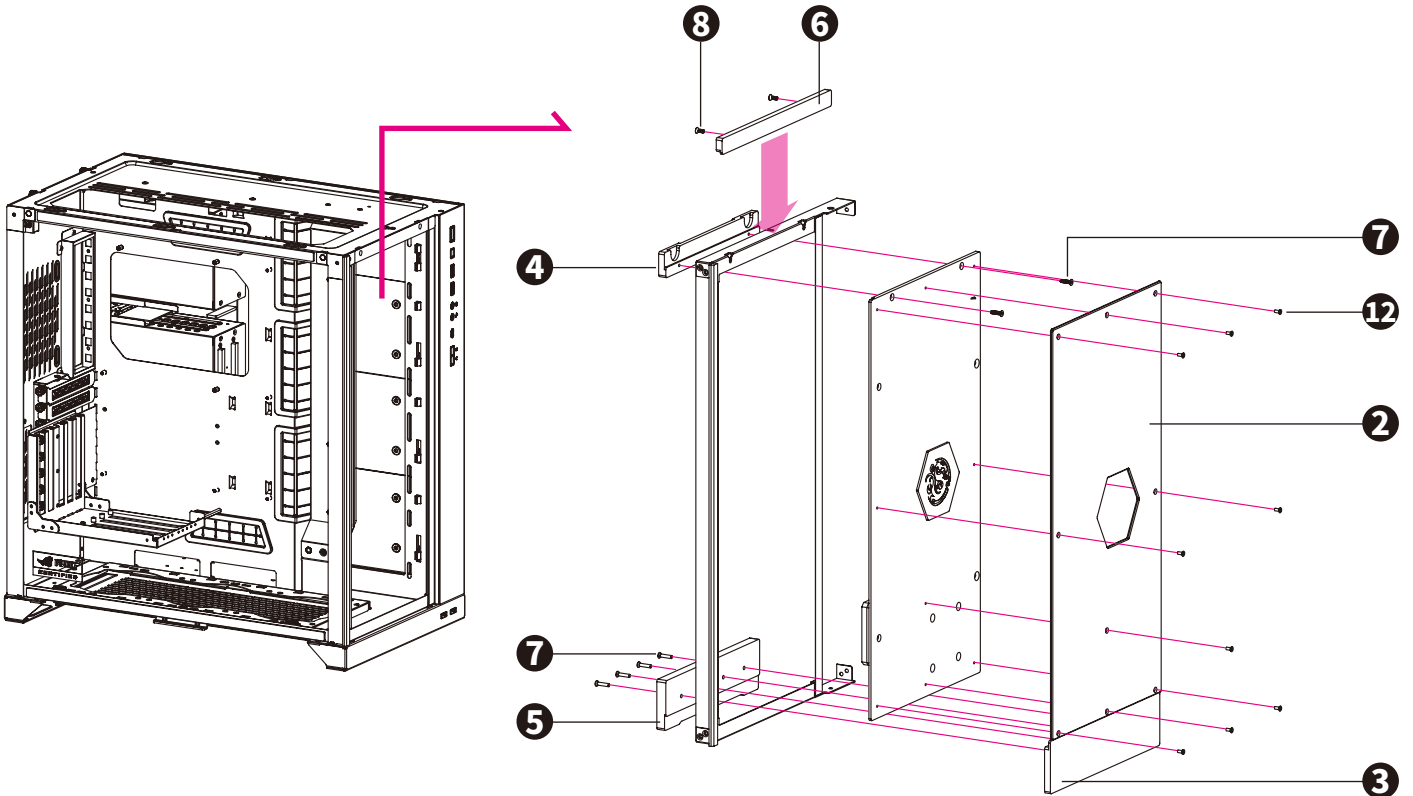



**BPTA-WDPO11DXLA-P5D 建议安装方式**

**主件说明 (需另购)**

<b>A</b> BP-NLXF360-F4PB	1PC	<b>H</b> BP-WTP-C06	3PCS
<b>B</b> BPTA-CPUMS-SKI	1PC	<b>I</b> BP-WTP-C61	1PC
<b>C</b> BP-VG2080RD	1PC	<b>J</b> BPTA-DRGBMFC	1PC
<b>D</b> BP-NCCLT14AC-L500	4PCS	<b>K</b> BP-PFANMFH	1PC
<b>E</b> BP-EML14	14PCS	<b>L</b> BP-DG14AALPII	2PCS
<b>F</b> BP-90R	8PCS		
<b>G</b> BPTA-EXAIR	1PC		

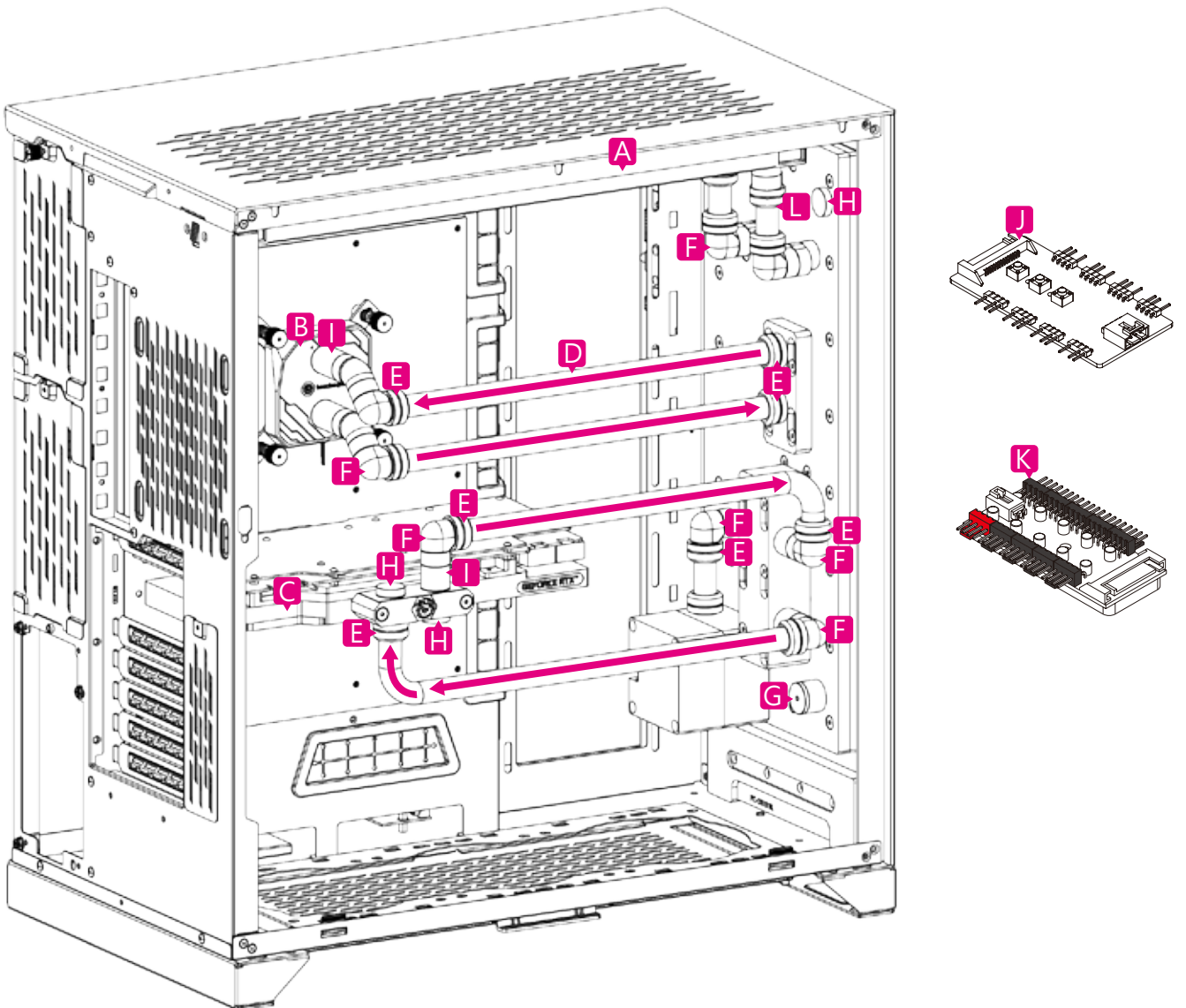

**BPTA-WDPO11DA-P5D 参考**

**步骤 1**

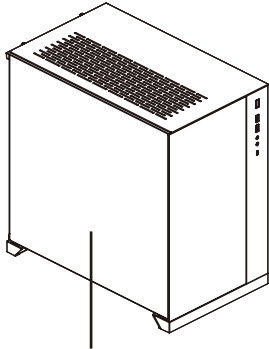

PC-O11 Dynamic  
(不包括)

**步骤 2**

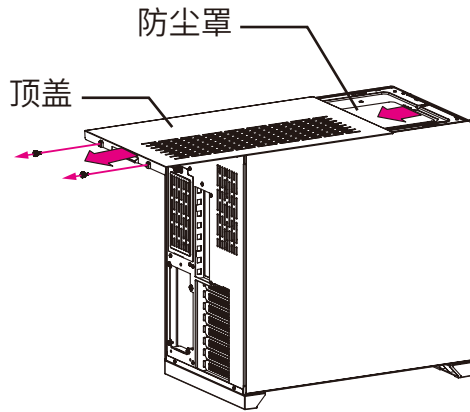

**步骤 3**

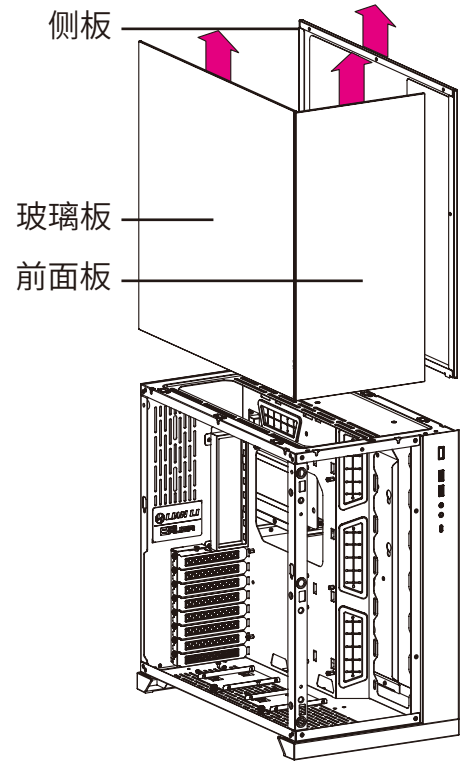

**步骤 4**

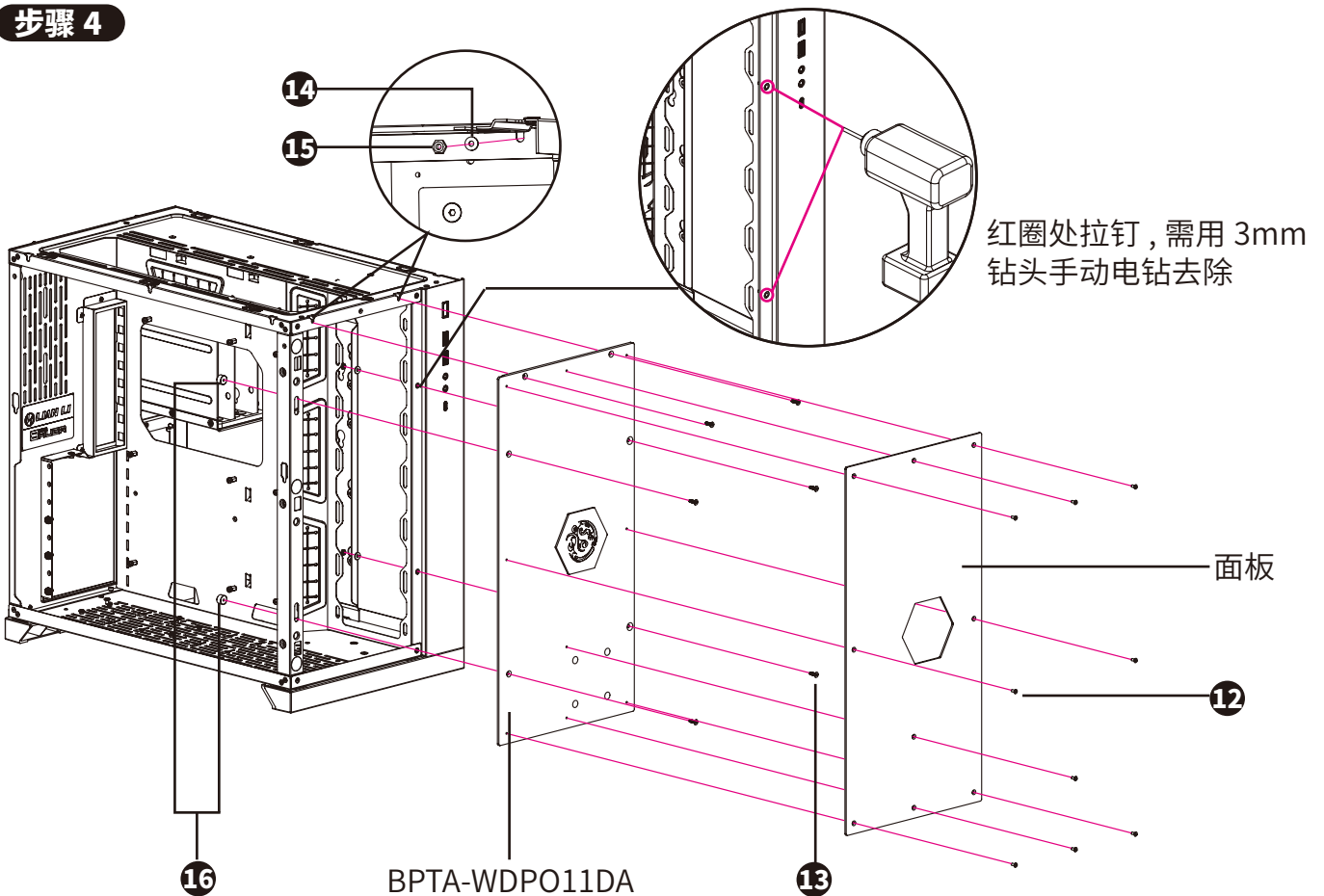



**BPTA-WDPO11DA-P5D 建议安装方式**
**主件说明 (需另购)**

<b>A</b> BPTA-NLSS360-F2PB	1PC	<b>H</b> BP-TB	1PC
<b>B</b> BPTA-CPUMS-DRGB	1PC	<b>I</b> BP-RG	1PC
<b>C</b> BP-VG2080RD	1PC	<b>J</b> BP-WTP-C06	3PCS
<b>D</b> BPTA-FX2212	3PCS	<b>K</b> BP-WTP-C60	1PC
<b>E</b> BP-DG14AALPII	2PCS	<b>L</b> BP-NCCLT14AC-L500	4PCS
<b>F</b> BP-EML14	10PCS	<b>M</b> BP-PFANMFH	1PC
<b>G</b> BP-90R	6PCS	<b>N</b> BPTA-DRGBMFC	1PCS

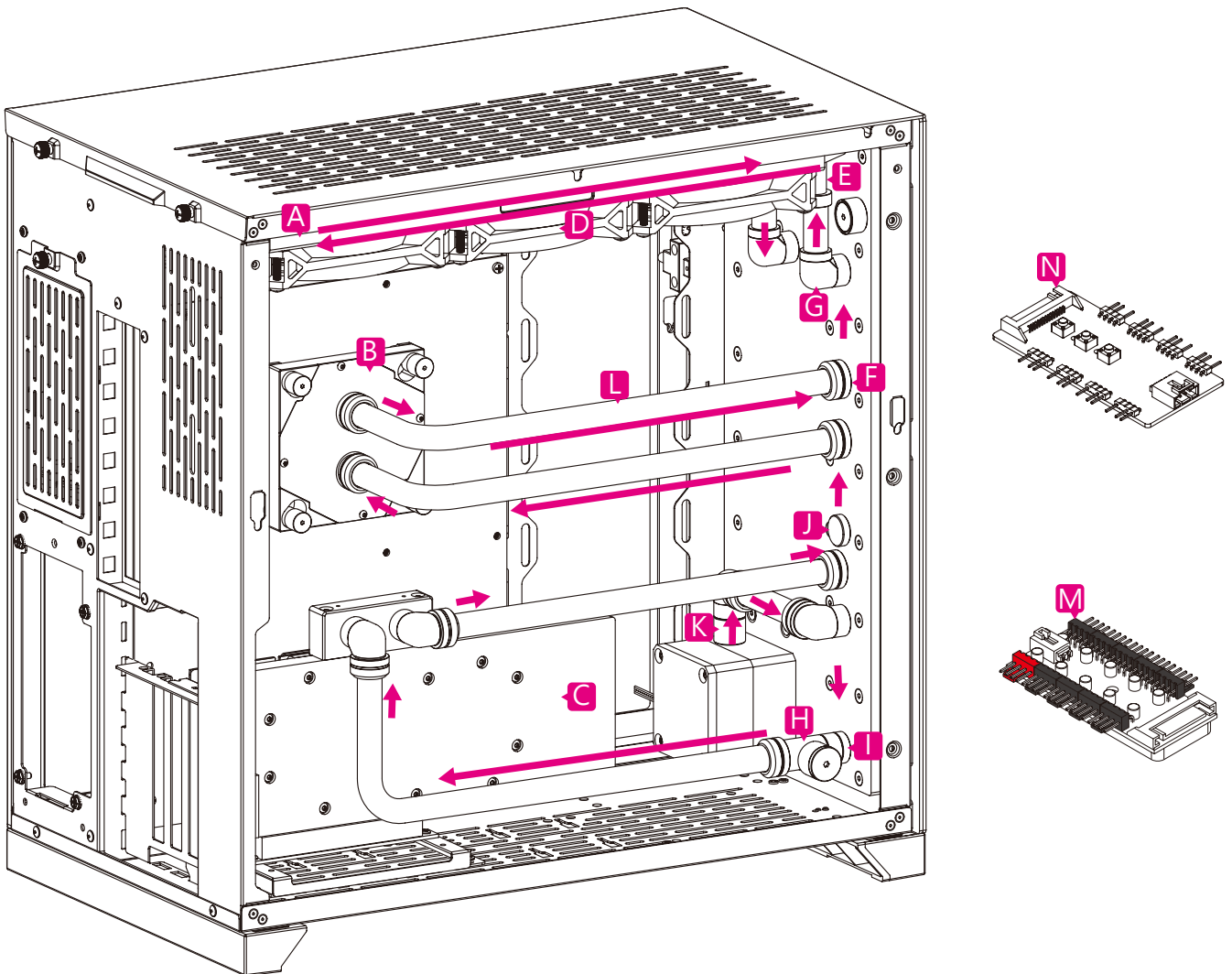

## 注意

- 跑水前，请先确认所有零件已安装在正确的位置上，在不开主机，单开水泵的情况下，进行 24 小时的跑水测试，确保无漏水情况后再开主机，避免发生漏水而导致电脑零件的损坏。
- 本公司保留对产品的设计更改以及解释的权力，如有更动恕不另行通知，产品颜色与配件以实物为准。
- 当使用测气产品测试水路时，为避免由于压力过大导致产品损坏，输入的压力请不要超过  $0.5\text{kg}/\text{cm}^2$  (Bar), 如因压力过大造成产品损坏，将由客户自行承担。严禁客户在水路有水及水泵开启的情况下进行气体饱压测试。
- Bitspower 建议消费者使用蒸馏水、纯净水，加入 Bitspower 的染剂作为水冷液使用；如客户自行选购的水冷液导致电镀层剥落、水道堵塞、水泵转动不正常、水箱管破裂或密封圈变型以致漏水等及其它不可抗力之问题时，消费者自行承担相关产品责任。未注水前，请勿启动水泵电源。